

Gas Mass Flow Meters with Digital Display

Features

- Direct monitoring of mass flow rate eliminates need for ancillary pressure and temperature sensing
- Digital display of mass flow rate on flow body or remote version for panel mounting
- Electronic output of mass flow rate for control or data-logging
- Fast response to changes in flow rate
- Large, straight sensor tube reduces contamination and maintenance down-time
- Platinum sensor eliminates zero drift and ensures long-term repeatability
- Primary standard calibration ensures starting point accuracy and NIST traceability
- CE Approved

SIERRA
INSTRUMENTS
THE MASS FLOW COMPANY



For information online...
www.sierrainstruments.com

820 Series Top-Trak™



Description

Sierra Instruments' Model 820 Top-Trak™ Mass Flow Meter is designed to replace volumetric flow rate devices at a comparable installed cost. No temperature or pressure corrections are required, as in the case of most other flow monitoring devices, such as rotometers, turbine meters or critical orifices.

Available in flow ranges from 0 to 10 sccm to 0 to 50 slpm, Top-Trak is suitable for any clean gas flow measurement application. Wetted surfaces are rugged 316 stainless steel, nickel plating, Nylon® plastic and Viton® "O" rings; all are corrosion-resistant.

The Model 820 measures and displays the mass flow rate directly in sccm or slpm. The integral instrument display is tiltable over 180° for easy viewing and can be removed for remote panel mounting. A 0–5 VDC or 4–20 mA output signal linearly proportional to gas mass flow rate is provided for recording, data-logging or control. This device is widely used in a variety of flow validation and calibration applications-by dozens of instrument OEMs and in a multitude of laboratory, test and analytical operations.

The information contained herein is subject to change without notice.

Dimensional Specifications

Model 820—Side View

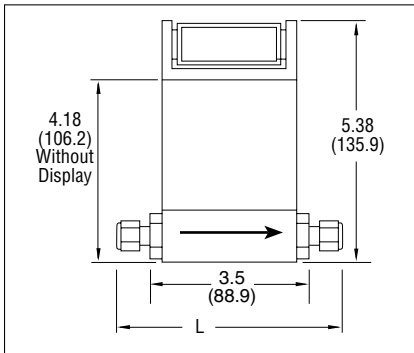

Model 820—Outlet View

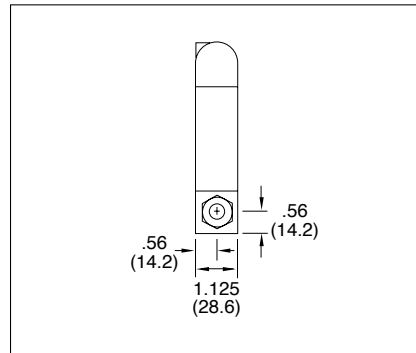

Model 820 —Bottom View

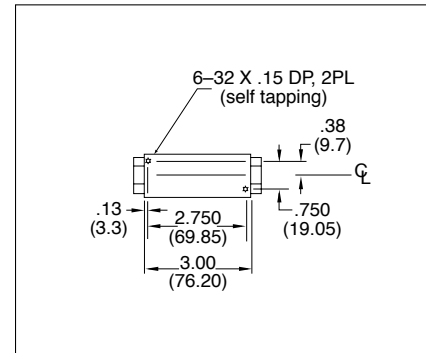

All dimensions are inches and in parentheses are millimeters. Certified drawings are available on request.

| | FITTING SIZE | | |
|--------|----------------------|----------------------|--------------|
| | 1/8-inch Compression | 1/4-inch Compression | 1/4-inch NPT |
| Dim. L | 5.51 (140.0) | 5.70 (144.8) | 3.50 (88.9) |

Performance Specifications

Accuracy

± 1.5 of full scale including linearity over
15° to 25°C and 5 to 60 psia (0.3 to 4 bara)
If the meter is mounted with a vertical (up or down) flow path
the following accuracy de-rating applies:

| Inlet Pressure Deviation ² | OPERATING PRESSURE | | |
|---------------------------------------|----------------------|----------------------|----------------------|
| | 50 psig | 100 psig | 150 psig |
| ± 1 psig | ± 1.5% of full scale | ± 1.5% of full scale | ± 1.5% of full scale |
| ± 5 psig | ± 3.8% of full scale | ± 4.5% of full scale | ± 5.3% of full scale |
| ± 10 psig | ± 6% of full scale | ± 7.5% of full scale | ± 9% of full scale |

Notes: (1) Do not exceed 150 psig.
(2) Difference between inlet pressure and calibrated pressure. Do not exceed ± 10 psig.

Repeatability

± 0.5% of full scale

Temperature Coefficient

0.08% of full scale per °F (0.15% of full scale per °C), or better

Pressure Coefficient

0.01% of full scale per psi (0.15% of full scale per bar), or better

Response Time

800 ms time constant; six seconds (typical) within
± 2% of final value over 25 to 100% of full scale

Operating Specifications

Gases

Most gases; check compatibility with wetted materials; specify when ordering

Mass Flow Rates

0 to 10 sccm to 0 to 50 slpm; flow ranges specified are for an equivalent flow
of nitrogen at 760 mm Hg and 21°C (70°F); other ranges in other units
are available (e.g., scfh or nm³/h)

Gas Pressure

150 psig (10 barg) maximum;
20 psig (1.4 barg) optimum

Gas & Ambient Temperature

32 to 122°F (0 to 50°C)

Leak Integrity

1 X 10⁻⁴ atm cc/sec of helium maximum

Pressure Drop

| PRESSURE DROP | | |
|---------------|-----------|-------------|
| | Flow Rate | cm of Water |
| 100 sccm | 0.06 | |
| | 1 slpm | 0.6 |
| | 10 slpm | 6.0 |
| | 20 slpm | 24.0 |
| | 30 slpm | 54.0 |
| | 40 slpm | 96.0 |
| | 50 slpm | 130.0 |

Power Requirements

12 to 15 VDC, 15 VDC nominal, 100 mA maximum
24 VDC optional

Output Signal

Linear 0–5 VDC, 1000 ohms minimum load resistance
Linear 4–20 mA, 500 ohms maximum loop resistance

Display

3.5 digit LCD (0.6 in H); removable for remote mounting

Physical Specifications

Wetted Materials

10% glass-filled Nylon[®] 6/6, 316 stainless steel, nickel plating,
Viton[®] "O"-rings standard
Neoprene[®] and 4079 Kal-Rez[®] "O"-rings optional

Options

See "Price List" for available CE options

Hi-Flow Gas Mass Flow Meters with Digital Display

Features

- Direct monitoring of mass flow rate eliminates need for ancillary pressure and temperature sensing
- Digital display of mass flow rate on flow body or remote version for panel mounting
- Aluminum flow body accommodates most gases in flow rates up to 175 slpm
- Electronic output of mass flow rate available for control or data-logging
- Large, straight sensor tube reduces contamination and maintenance down-time
- Platinum sensor eliminates zero-drift and ensures long-term repeatability
- Primary standard calibration ensures starting point accuracy and NIST traceability
- CE Approved

826/827 Series Top-Trak™



Description

Sierra Instruments' Model 826/827 Hi-Flow Top-Trak™ accurately measures the mass flow rate of most clean gases. Available in flow ranges from 0 to 75 slpm to 0 to 175 slpm. Wetted surfaces are anodized aluminum with Viton® "O" rings, and all are corrosion-resistant.

The Model 820 measures and displays the mass flow rate directly in sccm or slpm. The instrument is available with or without a digital display, which is tiltable over 180° for easy viewing and can be removed for remote panel mounting. A 0–5 VDC or 4–20 mA output signal linearly proportional to gas mass flow rate is provided for recording, data-logging or control. A 9-pin "D" connector for the output signal, input power, and remote display drive is standard.

Top-Trak's performance is unsurpassed: accuracy is 1.5% of full scale over a wide temperature and pressure range, and time response is two seconds to within 2% of final flow. This device is widely used in a variety of flow validation and calibration applications, by dozens of instrument OEMs, and in a multitude of laboratory, test and analytical operations.

Dimensional Specifications

Model 826—Side View

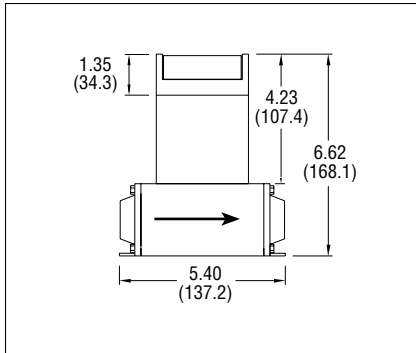

Model 826—Outlet View

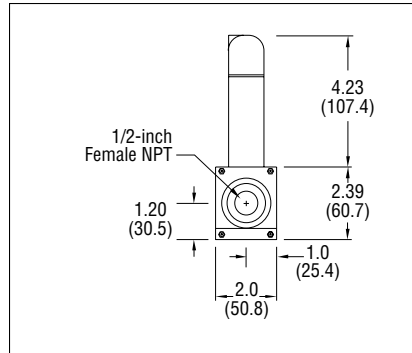

Model 826—Bottom View

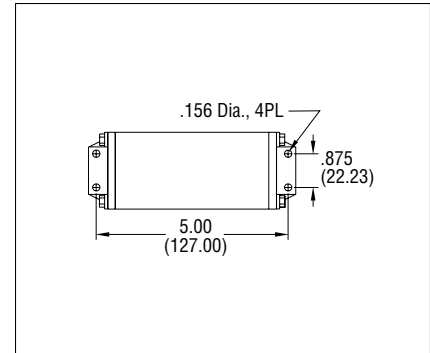

Model 827—Side View

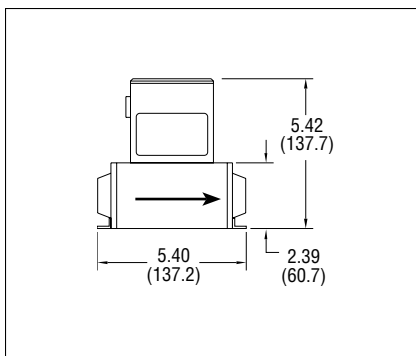

Model 827—Outlet View

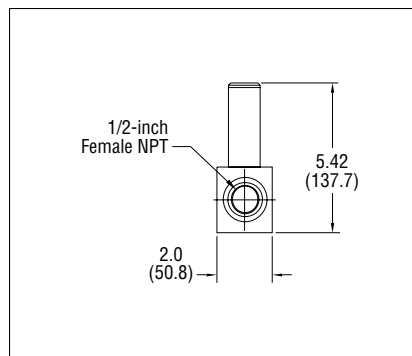

Model 827—Bottom View

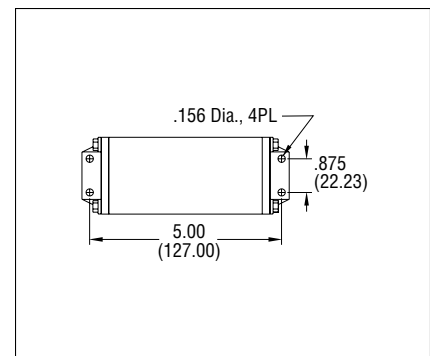

All dimensions are inches and in parentheses are millimeters. Certified drawings are available on request.

Performance Specifications

Accuracy

± 1.5 of full scale including linearity over
15° to 25°C and 5 to 60 psia (0.3 to 4 bara)

Repeatability

± 0.5% of full scale

Temperature Coefficient

0.08% of full scale per °F (0.15% of full scale per °C), or better

Pressure Coefficient

0.01% of full scale per psi (0.15% of full scale per bar), or better

Response Time

800 ms time constant; six seconds (typical) to within
± 2% of final value over 25 to 100% of full scale

Pressure Drop

Two inches of mercury maximum at 175 slpm

Gas & Ambient Temperature

32 to 122°F (0 to 50°C)

Leak Integrity

1 X 10⁻⁴ atm cc/sec of helium maximum

Power Requirements

12 to 18 VDC, 15 VDC nominal, 100 mA maximum
24 VDC optional

Output Signal

Linear 0–5 VDC, 1000 ohms minimum load resistance
Linear 4–20 mA, 500 ohms maximum loop resistance

Display

3.5 digit LCD (0.6 in H); removable for remote mounting

Operating Specifications

Gases

Most gases; check compatibility with wetted materials; specify when ordering

Mass Flow Rates

0 to 75 to 0 to 175 slpm; flow range is for an equivalent flow of nitrogen at
760 mm Hg and 21°C (70°F); other ranges in other units are available
(e.g., scfh or nm³/h)

Gas Pressure

150 psig (10 barg) maximum;
20 psig (1.4 barg) optimum

Physical Specifications

Wetted Material

Anodized aluminum, 316 stainless steel, nickel plating,
Viton® “O”-rings standard
Neoprene® and 4079 Kal-Rez® “O”-rings optional

STRAIGHT PIPE LENGTH REQUIREMENTS (In Number of Internal Diameters, D)

| | |
|--|------|
| 1/2 inch Female NPT, minimum, upstream | 10 D |
| 1/2 inch Female NPT, minimum, downstream | 5 D |

Ordering the Model 820, 826 or 827

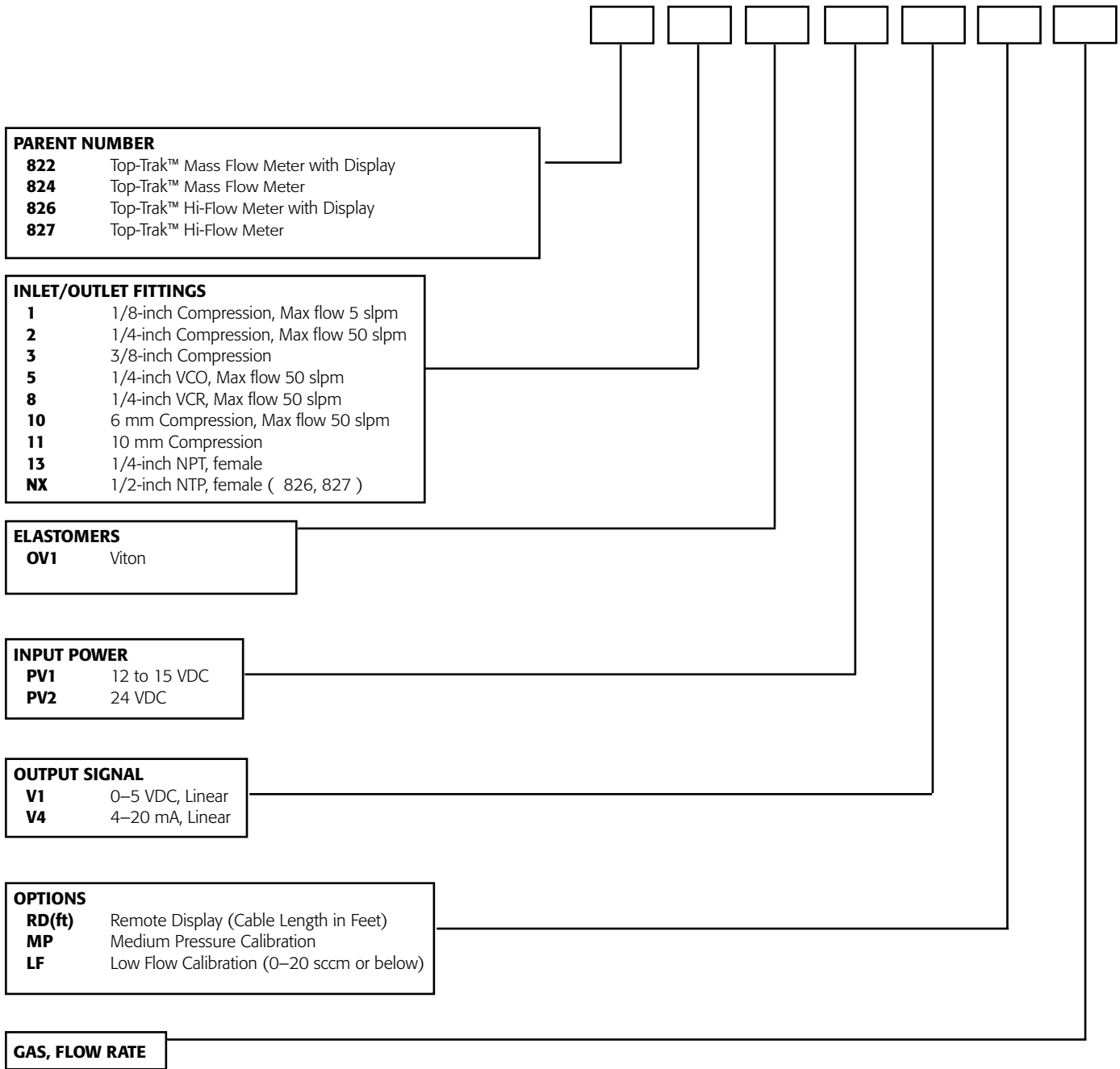

ACCESSORIES (Consult Factory)
CONNECTORS AND CABLES (Consult Factory)

SIERRA INSTRUMENTS, NORTH AMERICA • 5 Harris Court, Building L • Monterey, California • (800) 866-0200 • (831) 373-0200 • Fax (831) 373-4402 • www.sierrainstruments.com

SIERRA INSTRUMENTS, EUROPE • Bijlmansweid 2 • 1934RE Egmond aan den Hoef • The Netherlands • +31 72 5071400 • Fax: +31 72 5071401

SIERRA INSTRUMENTS, ASIA • Rm.618, Tomson Centre, Bldg. A • 188 Zhang Yang Road • Pu Dong New District • Shanghai, P.R. China 200122 • +8621 5879 8521/22 • Fax: +8621 5879 8586